

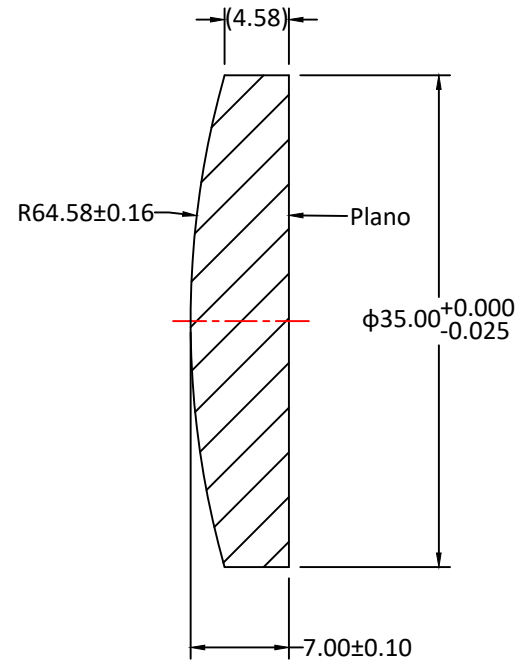

RADIUS	R TOL	POWER	IRRG	CA	DIA	DIA TOL	MATERIAL	INDEX	CT	CT TOL
64.58 CX	±0.16	3	0.5	90%	35.00	+0/-0.025	H-K9L	517642	7.00	±0.10
Plano	-	3	0.5	90%						

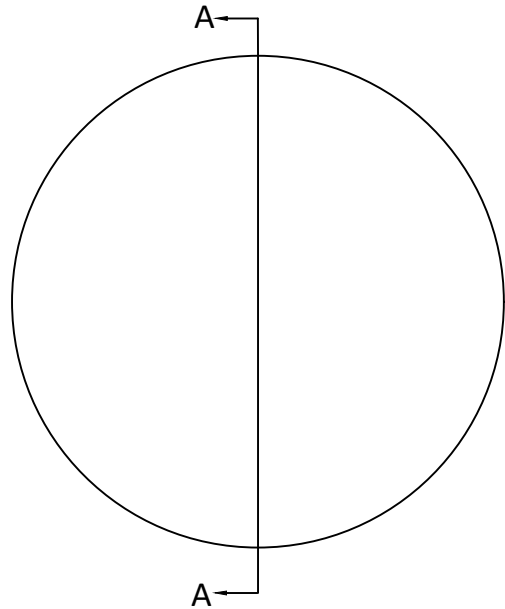

SECTION A-A

Notes:

1. ALL DIMENSIONS IN MM
2. TOLERANCE UNLESS SPECIFIED ± 0.10
3. MATERIAL: OPTICAL GLASS H-K9L
4. MANUFACTURE PER MIL-PRF-13830
5. POLISH TO TESTPLATE WITHIN POWER AND IRREGULARITY INDICATED (FRINGES)
6. FOCAL LENGTH(EFL): 125.00±1%
7. SURFACE QUALITY : 40-20 SCRATCH-DIG
8. CHAMFER EDGES: 0.5×45°MAX UNLESS SPECIFIED
9. CENTRATION TOLERANCE: 1.0' MINUTES MAX
10. COATING: S1 & S2: Ravg<0.5% @1050-1700nm @ 0°AOI

UNLESS OTHERWISE SPECIFIED:		NAME	DATE	
DIMENSIONS ARE IN mm TOLERANCES: FRACTIONAL ± ANGULAR: ±3 ARC MIN TWO PLACE DECIMAL: ±0.10 THREE PLACE DECIMAL: ±0.05		DRAWN	Sally Song	
INTERPRET GEOMETRIC TOLERANCING PER:		CHECK		
MATERIAL H-K9L		ENG APPR.		
FINISH		MFG APPR.		
DO NOT SCALE DRAWING		QA	Ann Chen	12.18.24
PROJECT NO.		COMMENTS		TITLE: DIAMETER 35.00MM, EFL 125.00MM, H-K9L, NIR 2 COATED, PLANO-CONVEX LENS
SCALE:		SIZE	DWG.NO.	REV
WEIGHT:		A	L-PX0060125035	0
SHEET 1 OF 1				