

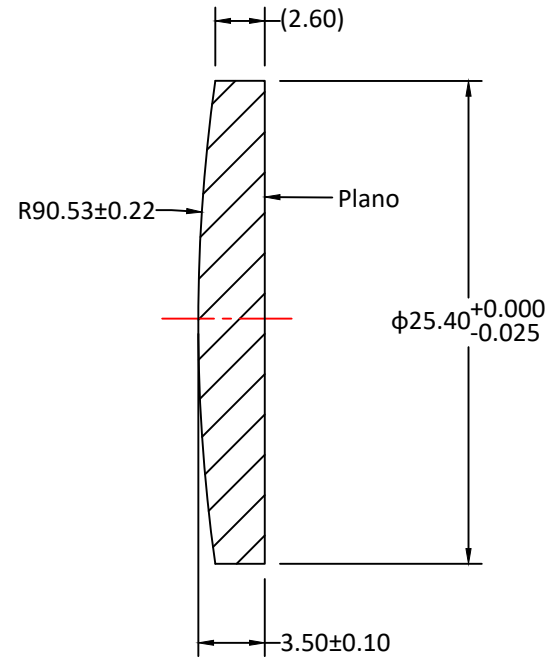

| RADIUS | R TOL | POWER | IRRG | CA | DIA | DIA TOL | MATERIAL | INDEX | CT | CT TOL |
|----------|-------|-------|------|-----|-------|-----------|----------|--------|------|--------|
| 90.53 CX | ±0.22 | 3 | 0.5 | 90% | 25.40 | +0/-0.025 | H-K9L | 517642 | 3.50 | ±0.10 |
| Plano | - | 3 | 0.5 | 90% | | | | | | |

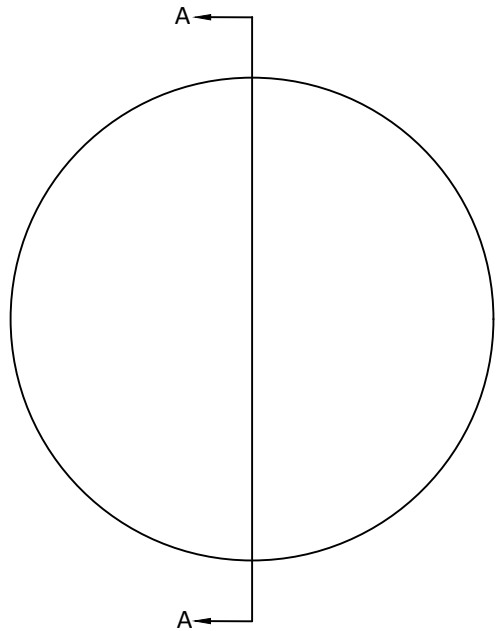

SECTION A-A

Notes:

1. ALL DIMENSIONS IN MM
2. TOLERANCE UNLESS SPECIFIED ± 0.10
3. MATERIAL: OPTICAL GLASS H-K9L
4. MANUFACTURE PER MIL-PRF-13830
5. POLISH TO TESTPLATE WITHIN POWER AND IRREGULARITY INDICATED (FRINGES)
6. FOCAL LENGTH(EFL): 175.00±1%
7. SURFACE QUALITY : 40-20 SCRATCH-DIG
8. CHAMFER EDGES: 0.5×45°MAX UNLESS SPECIFIED
9. CENTRATION TOLERANCE: 1.0' MINUTES MAX
10. COATING: S1 & S2: Ravg 0.5% @ 630-1100nm @ 0°AOI

| | | | | |
|--------------------------------------|----------------|------------------------------------------------------------------------|------------|---------------------------------------------------------------------------------------|
| UNLESS OTHERWISE SPECIFIED: | | NAME | DATE |  |
| DIMENSIONS ARE IN mm | | DRAWN | Sally Song | |
| TOLERANCES: | | CHECK | | |
| FRACTIONAL ± | | ENG APPR. | | |
| ANGULAR: ±3 ARC MIN | | MFG APPR. | | |
| TWO PLACE DECIMAL: ±0.10 | | QA | Ann Chen | 12.18.24 |
| THREE PLACE DECIMAL: ±0.05 | | COMMENTS | | |
| INTERPRET GEOMETRIC TOLERANCING PER: | | | | |
| MATERIAL H-K9L | | | | |
| FINISH | | | | |
| DO NOT SCALE DRAWING | | PROJECT NO. | | |
| | | TITLE: | |  |
| | | DIAMETER 25.40MM, EFL 175.00MM, H-K9L, NIR 1 COATED, PLANO-CONVEX LENS | | |
| SIZE | DWG.NO. | | REV | |
| A | L-PX005017525Z | | 0 | |
| SCALE: | WEIGHT: | SHEET 1 OF 1 | | |