

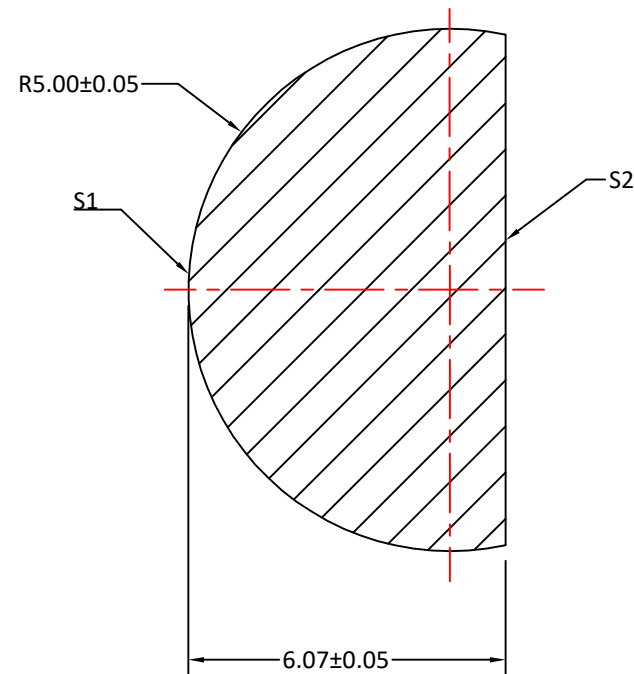

RADIUS	R TOL	POWER	IRRG	CA	DIA	DIA TOL	MATERIAL	INDEX	CT	CT TOL
5.00	±0.05	-	-	-	10.00	+0/-0.10	Silicon		6.07	±0.05
Plano	-	-	-	-						

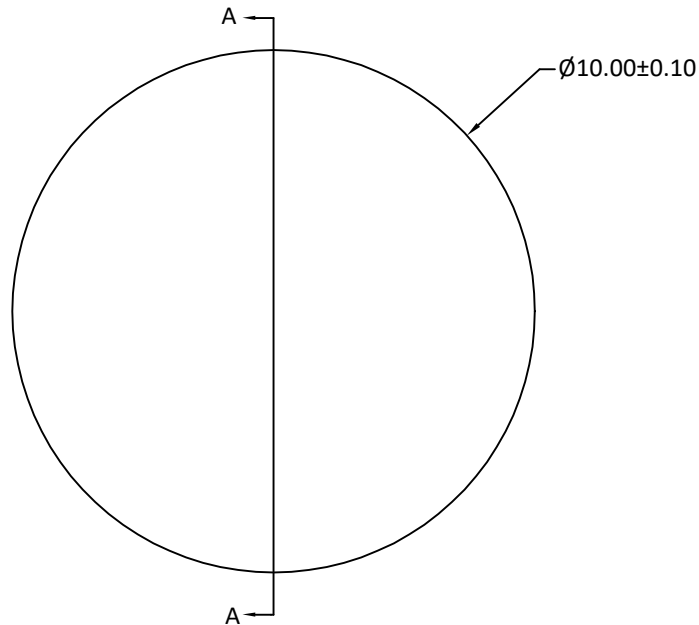

SECTION A-A

Notes:

1. ALL DIMENSIONS IN MM
2. MATERIAL: HRFZ-SILICON, RESISTANCE > 10kΩ*cm
3. S1: HYPER-HEMISPHERICAL, POLISHED
4. S2: FLAT, POLISHED
5. CLEAR APERTURE: ≥90% OF DIAMETER
6. SURFACE QUALITY: 60-40 SCRATCH-DIG
7. THICKNESS TOLERANCE: 0.05mm
8. SURFACE ACCURACY: ±0.01mm DEVIATION FROM IDEAL SPHERE AND PLANE

UNLESS OTHERWISE SPECIFIED:		NAME	DATE	
DIMENSIONS ARE IN mm TOLERANCES: FRACTIONAL ± ANGULAR: ±3 ARC MIN TWO PLACE DECIMAL: ±0.10 THREE PLACE DECIMAL: ±0.05		DRAWN	Sally Song	
INTERPRET GEOMETRIC TOLERANCING PER:		CHECK		
MATERIAL SILICON		ENG APPR.		
FINISH		MFG APPR.		
DO NOT SCALE DRAWING		QA		
PROJECT NO.		COMMENTS		TITLE: 10.00 DIAMETER, 6.07 THICKNESS TERAHERTZ SILICON HYPER BALL LENS
SCALE:		SIZE	DWG.NO.	REV
WEIGHT:		A	CLZ-Hyper-10-607	0
SHEET 1 OF 1				